

From Off-The-Shelf to Market-Ready© New Age Enclosures is your Single Source Solution.
Let us quote modifying our Stock Enclosures to meet your end-use.
visit newageenclosures.com/services or call 855-4NA-ENCL today.

CNC CUTOUTS
PART DECORATING
CUSTOM COLOR AND MATERIAL
RF/EMI SHEILDING
CUSTOM TOOL INSERTS
CUSTOM ENCLOSURES AND DESIGN



NEW AGE
ENCLOSURES

DEVELOP THE FUTURE



NOTES: UNLESS OTHERWISE SPECIFIED

1. CORNERS DRAWN SHARP TO BE R.005 MAXIMUM.
2. EXTERIOR SURFACE TEXTURE TO BE LIGHT EDM FINISH. EQUIVELANT TO MT-11010.
3. INTERIOR SURFACE TEXTURE: NONE
4. ALL INSIDE RADII .010R. UNLESS OTHERWISE SPECIFIED.
5. ALL EXTERNAL DIMENSIONS AFFECTED BY THE DRAFT APPLY AT THE LARGE END OF THE FEATURE, AND ALL INTERNAL FEATURES AFFECTED BY THE DRAFT APPLY AT THE SMALL END OF THE FEATURE UNLESS OTHERWISE SPECIFIED.
6. 1 DEGREES DRAFT IN THE DIRECTION OF PULL IS PERMISSIBLE UNLESS OTHERWISE SPECIFIED.
7. THIS ENCLOSURE IS A PRESS FIT ASSEMBLY. FOR PERMANENT CLOSURE: A DROP ADHESIVE OR ULTRASONIC WELDING IS REQUIRED.
8. MATERIAL / COLOR: ABS PLASTIC IS STANDARD IN BLACK OR WHITE. CUSTOM MATERIALS AND COLORS ARE AVAILABLE UPON REQUEST FOR QUOTE.
9. PCB SIZES ARE RECOMMENDATIONS ONLY. FINAL SIZES AND VERIFICATION OF IT'S FIT ARE THE SOLE RESPONSIBILITY OF EACH OWNER.
10. THE GATE REMNANT FOR THIS ENCLOSURE IS LOCATED IN THIS POSITION TO MINIMIZE ANY COSMETIC IMPACT. IT IS HOWEVER VISIBLE AND VARIES IN SIZE / SHAPE. IT IS EASILY REMOVED WITH CLIPPERS. IF YOU WOULD LIKE NEW AGE TO CLIP THIS FOR YOU, PLEASE ASK YOUR SALES REPRESENTIVE FOR A FREE QUOTE.

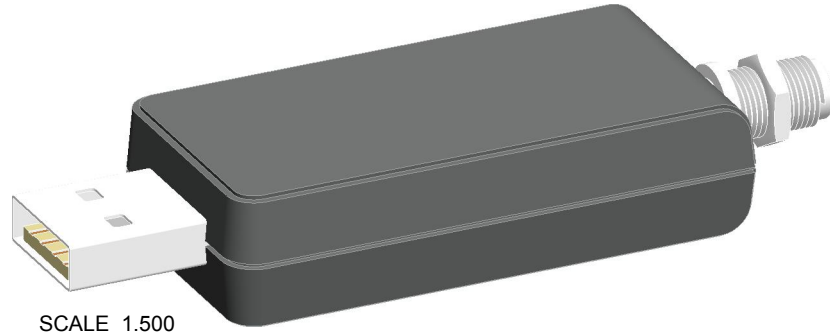

SCALE 1.500

R E V I S I O N					
REV.	DRAWN BY	ECO No	DESCRIPTION	DATE	APPROVED
1	M BOYER		PRELIMINARY RELEASE	21-May-07	D.C.
2	M BOYER		ADD WIDE PCB CONFIGURATION	06-Jun-07	D.C.
3	M BOYER		MOVE PCB POSTS OUTWARD .03 PER SIDE	30-Jul-07	D.C.
4	M BOYER		UPDATE TO AS BUILT	12-Oct-07	D.C.
5	M BOYER	0208	UPDATE FORMAT AND RELEASE	04-Apr-08	D.C.
5.1	M BOYER	0710	UPDATE FORMAT	30-Mar-10	D.C.
5.2	M BOYER	0810	ADD NOTE 10	08-Apr-10	D.C.
6.0	M BOYER	2910	UPDATE BOARD THICKNESS INFORMATION	16-Aug-10	D.C.
6.1	M BOYER	3010	DOCUMENT CHANGE	24-Aug-10	D.C.
6.2	M BOYER	2711	CHANGE ASSEMBLY DIMENSIONS TO "PRESS FIT"	21-Oct-11	D.C.
7.0	M BOYER	1913	INCLUDE .062" PCB OPTION	09-Apr-13	D.C.
7.1	R CRUZ	8713	REMOVE .062" COVER OPTION	18-Dec-13	D.C.
7.2	M BOYER	1823	INCLUDE TYPE C CONFIGURATION	2023-Nov-08	D.C.
7.3	M BOYER	00524	REMOVE .031 PCB TYPE C OPTION	2024-Apr-09	

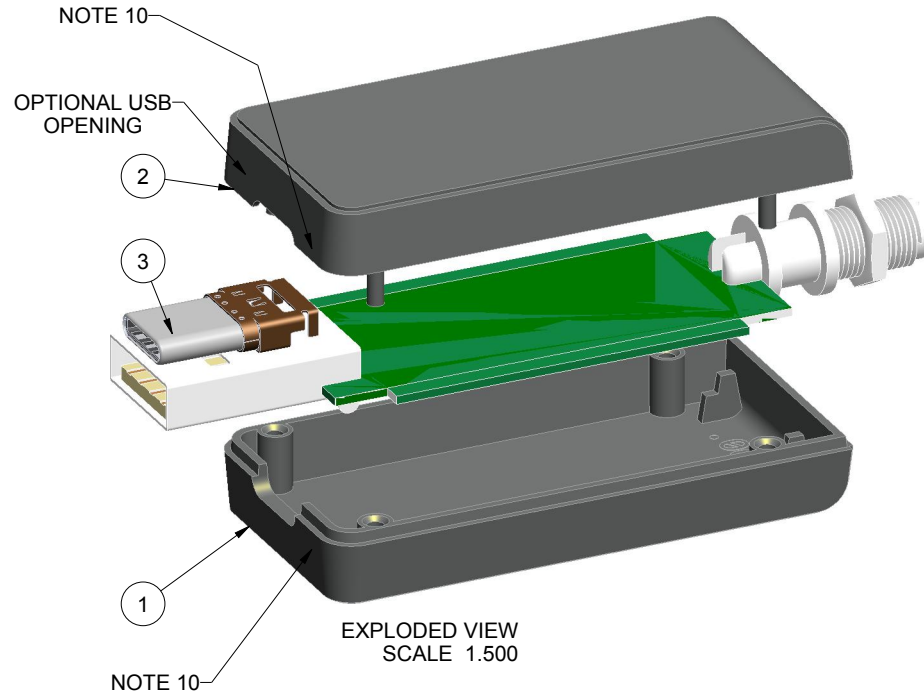

P201005(x) CONFIGURATIONS					
	-S	-U	-62S	-62U	-62C
201005 COVER	1		1		
201005 COVER w/ TYPE A USB OPENING		1		1	
201005 COVER w/ TYPE C USB OPENING					1
201005 BASE	1				
201005 BASE (.062" PCB)			1		
201005 BASE w/ TYPE A USB OPENING		1			
201005 BASE (.062" PCB) w/ TYPE A USB OPENING				1	
201005 BASE (.062" PCB) w/ TYPE C USB OPENING					1

ITEM	FILE NAME	DESCRIPTION	MATERIAL	COLOR	QTY.
4	USB-C_CONNECTOR	SMT USB-C	REFERENCE	CUSTOMER SUPPLIED	1
3	201005_PCB	201005 PCB - REFERENCE	.031" THICK	CUSTOMER SUPPLIED	1
2	201005_COVER	201005U COVER - STANDARD	ABS	BLACK or WHITE	1
1	201005_BASE	201005U BASE - STANDARD	ABS	BLACK or WHITE	1

BILL OF MATERIALS

THIRD ANGLE PROJECTION DO NOT SCALE DRAWING	TOLERANCES: UNLESS OTHERWISE SPECIFIED DIMENSIONS ARE IN U.S. INCHES. X.XX = .015 X.XXXX = .001 X.XXX = .010 X.X" = 1"	NEW AGE ENCLOSURES 2240 South Thornburg Street Santa Maria, CA. 93455 ph. (805) 595-1310 fax (805) 595-1024 www.newageenclosures.com
	Customer's Part No: 201005X	
APPROVAL BY DATE CHECK _____ ENG. _____ SCALE AS NOTED	DRAWN BY M BOYER DATE 2007-May-21	SIZE A DRAWING NAME 201005_R7_3 SHEET 1 OF 6 REV.DOC 7.3

201005 X ASSEMBLY

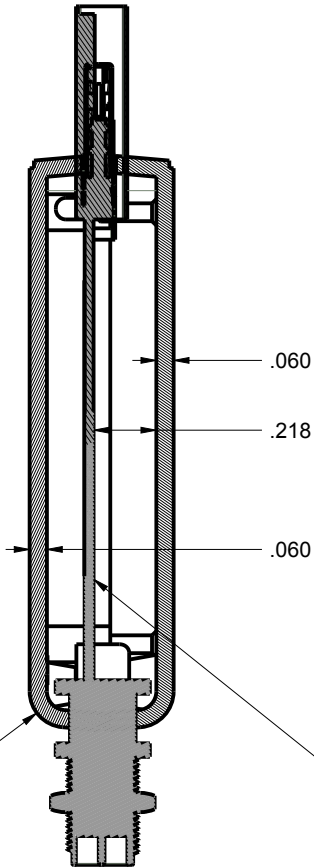
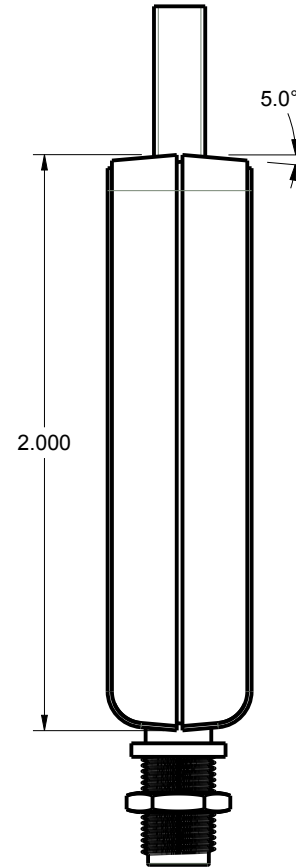
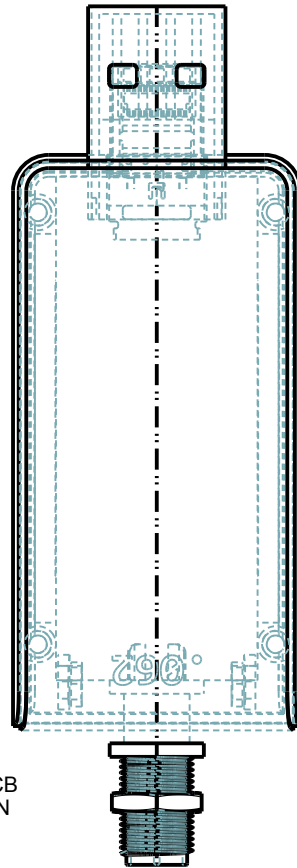
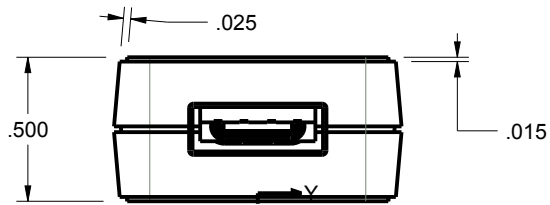

R.125

SHOWN WITH .031" PCB
ORDER "-62" VERSION
FOR OPTIONAL PCB
THICKNESS

SCALE 1.500

SECTION Y-Y

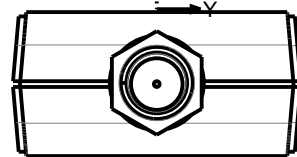

TOLERANCES: UNLESS OTHERWISE SPECIFIED DIMENSIONS ARE IN U.S. INCHES.		NEW AGE ENCLOSURES	
X.XX = .015 X.XXXX = .001		2240 South Thornburg Street Santa Maria, CA. 93455	
X.XXX = .010 X.X' = 1°		ph. (805) 595-1310 fax (805) 595-1024	
NEW AGE ENCLOSURES		www.newageenclosures.com	
Customer's Part No: 201005X			
APPROVAL	BY	DATE	
CHECK			
ENG.			
SCALE	AS NOTED		
DRAWN BY	SIZE	DRAWING NAME	SHEET
M BOYER	2007-May-21	A 201005_R7_3	2 OF 6
			REV.DOC
			7.3

STANDARD - USB DEVICE
PXX-201005X-XXX

201005U COVER

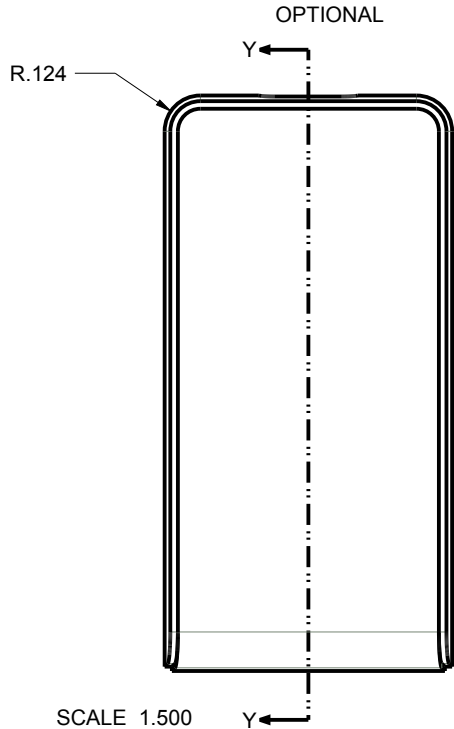
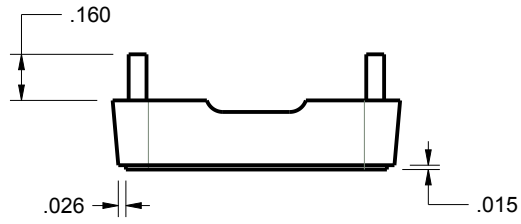

SCALE 1.500

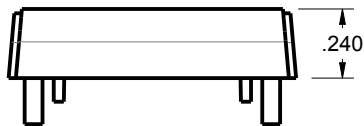
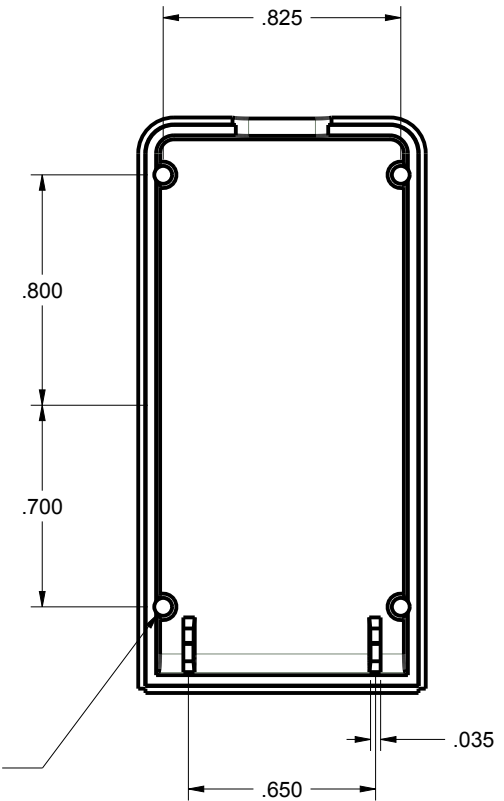
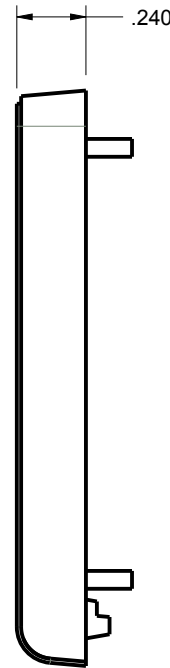
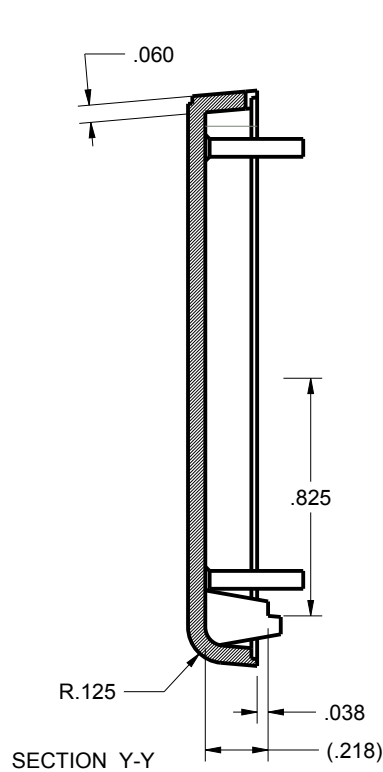

TOLERANCES: UNLESS OTHERWISE SPECIFIED DIMENSIONS ARE IN U.S. INCHES. X.XX = .015 X.XXXX = .001 X.XXX = .010 X.X° = 1°		NEW AGE ENCLOSURES	
NEW AGE ENCLOSURES		2240 South Thornburg Street Santa Maria, CA. 93455 ph. (805) 595-1310 fax (805) 595-1024 www.newageenclosures.com	
Customer's Part No: 201005X			
APPROVAL	BY	DATE	
CHECK			
ENG.			
SCALE	AS NOTED		
DRAWN BY	SIZE	DRAWING NAME	SHEET
M BOYER	2007-May-21	A 201005_R7_3	3 OF 6
STANDARD - USB DEVICE PXX-201005X-XXX			REV.DOC 7.3

NO DRAFT

20100562U BASE

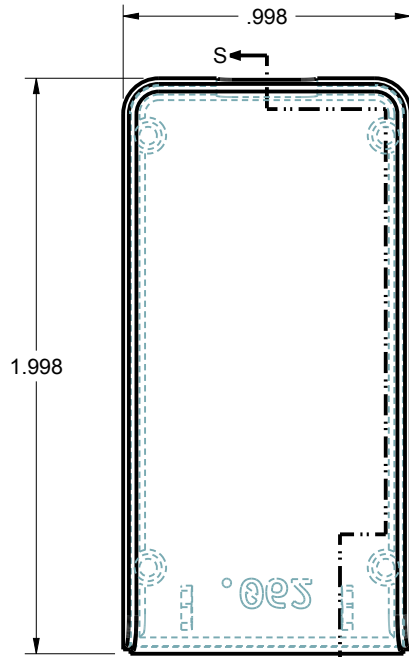

SCALE 1.500 S

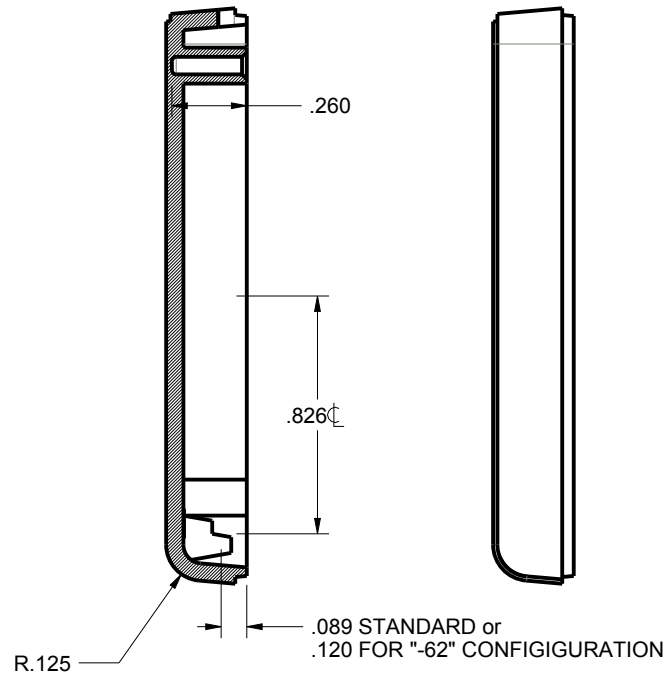

SECTION S-S

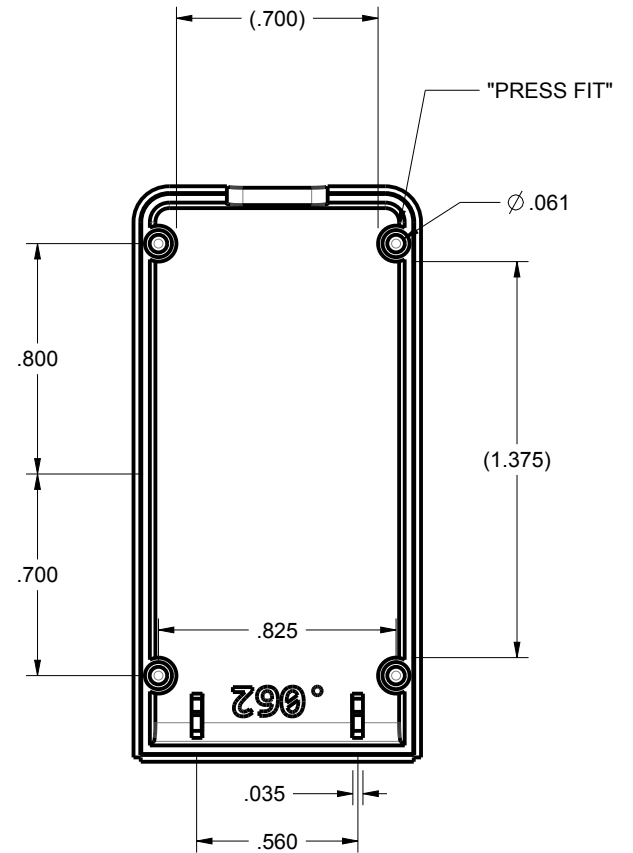

TOLERANCES: UNLESS OTHERWISE SPECIFIED
DIMENSIONS ARE IN U.S. INCHES.
X.XX = .015 X.XXXX = .001
X.XXX = .010 X.X° = 1°

NEW AGE ENCLOSURES
2240 South Thornburg Street Santa Maria, CA. 93455
ph. (805) 595-1310 fax (805) 595-1024
www.newageenclosures.com

Customer's Part No: 201005X

APPROVAL	BY	DATE
CHECK		
ENG.		
SCALE	AS NOTED	

STANDARD - USB DEVICE
PXX-201005X-XXX

DRAWN BY
M BOYER 2007-May-21

SIZE A DRAWING NAME
201005_R7_3

SHEET 4 OF 6 REV.DOC 7.3

201005 PCB - CUSTOMER SUPPLIED

PCB SIZES ARE RECOMMENDATIONS ONLY. FINAL SIZES AND VERIFICATION OF IT'S FIT ARE THE SOLE RESPONSIBILITY OF THE OEM.

SUGGESTED (Reference)
 USB 3.2 Gen2 TYPE C PLUG
 CONNECTOR, HORIZONTAL, SMT
 GLOBAL CONNECTOR TECHNOLOGY, LTD
 www.gtc.co PN. USB4155

SUGGESTED (Reference)
 TYPE A USB PLUG CONNECTOR
 ACON, ADVANCED CONNECTEK INC.
 PN. C-UAR70-00-00
 www.acon/en-global/product/detail/378

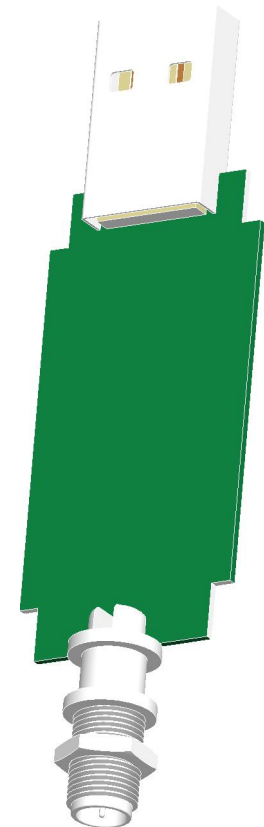

SCALE 1.500

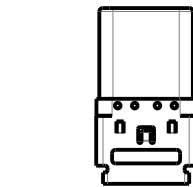

SCALE 1.500

EXTENDED SIDES
 ARE OPTIONAL

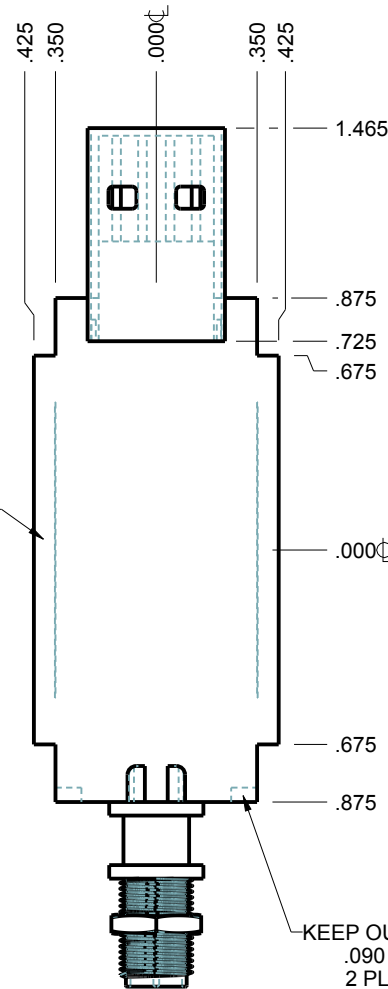

SCALE 1.500

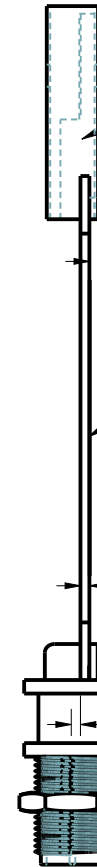

FOR .062" PCB THICKNESS
 ORDER "-62" CONFIGURATION

** = RECOMMENDED BOARD THICKNESS IS .031" or .062" THICK, OPTIONS ARE AVAILABLE TO ALLOW OTHER THICKNESSES. ASK YOUR SALES REP FOR A QUOTE.

TOLERANCES: UNLESS OTHERWISE SPECIFIED
 DIMENSIONS ARE IN U.S. INCHES.
 X.XX = .015 X.XXXX = .001
 X.XXX = .010 X.X° = 1°

NEW AGE ENCLOSURES

Customer's Part No: 201005X

APPROVAL	BY	DATE
CHECK		
ENG.		
SCALE	AS NOTED	

DRAWN BY
 M BOYER 2007-May-21

NEW AGE ENCLOSURES

2240 South Thornburg Street Santa Maria, CA. 93455
 ph. (805) 595-1310 fax (805) 595-1024
 www.newageenclosures.com

STANDARD - USB DEVICE
 PXX-201005X-XXX

SIZE	DRAWING NAME	SHEET	REV.DOC
A	201005_R7_3	5 OF 6	7.3

2nd OPERATION DETAILS

New Age Enclosures DELIVERS YOUR ENCLOSURE MARKET-READY WITH IN-HOUSE
CNC MACHINING, PAD PRINTING, ASSEMBLY, AND FULFILLMENT.
ALL SURFACES AND AREAS ARE AVAILABLE FOR CNC ALTERATION BY New Age Enclosures
CALL (805) 595-1310 FOR PRICING AND SCHEDULE.
THE INSIDE RADIUS OF ANY MACHINED FEATURES SHOULD BE NO SMALLER THAN .031"

MOLDED USB
OPENING

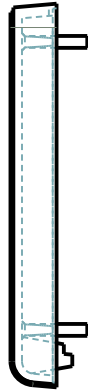
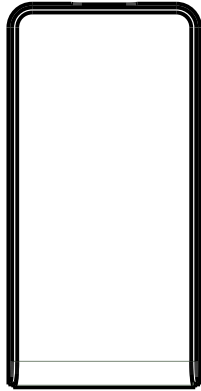
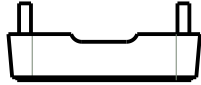

201005U COVER
SCALE 1.000

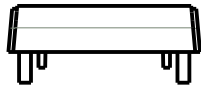

MOLDED USB
OPENING

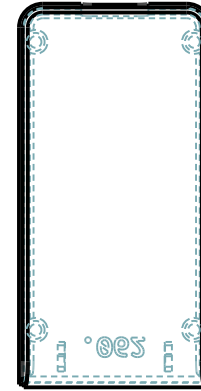

201005U BASE
SCALE 1.000



PXX-201005U-XXX COVER - ABS, BLACK

STEP NO	DESCRIPTION	CUTTER	FIXTURE	ORIENTATION	PROGRAM
1-C-C1	-	T2 = .062" EM	268	-	o1000
2-C-C2	-	T2 = .062" EM	268	-	o1001

PXX-201005U-XXX BASE - ABS, BLACK

STEP NO	DESCRIPTION	CUTTER	FIXTURE	ORIENTATION	PROGRAM
3-B-C1	-	T2 = .062" EM	268	-	o1002
4-B-C2	-	T2 = .062" EM	268	-	o1003

TOLERANCES: UNLESS OTHERWISE SPECIFIED
DIMENSIONS ARE IN U.S. INCHES.
X.XX = .015 X.XXXX = .001
X.XXX = .010 X.X° = 1°

NEW AGE ENCLOSURES
Customer's Part No: 201005X

APPROVAL	BY	DATE
CHECK		
ENG.		
SCALE	AS NOTED	
DRAWN BY	M BOYER	
	2007-May-21	

NEW AGE ENCLOSURES

2240 South Thornburg Street Santa Maria, CA. 93455
ph. (805) 595-1310 fax (805) 595-1024
www.newageenclosures.com

STANDARD - USB DEVICE PXX-201005X-XXX

SIZE	DRAWING NAME	SHEET	REV.DOC
A	201005_R7_3	6 OF 6	7.3