

# From Off-The-Shelf to Market-Ready© New Age Enclosures is your Single Source Solution.



**Get a free quote today.**

Visit [newageenclosures.com/services](http://newageenclosures.com/services) or  
call 855-4NA-ENCL for customization.

Part Marking  
CNC Cutouts  
Color Options  
RF/EMI Shielding  
Specialized Materials  
Custom Designed Enclosures

**NEW AGE  
ENCLOSURES**

DEVELOP THE FUTURE

**20+** YEARS  
of LEADING BY DESIGN



NOTES: UNLESS OTHERWISE SPECIFIED

- CORNERS DRAWN SHARP TO BE R.005 MAXIMUM.
- EXTERIOR SURFACE TEXTURE TO BE LIGHT EDM FINISH. EQUIVELANT TO MT-11020. CENTER PART TO BE POLISHED.
- INTERIOR SURFACE TEXTURE TO BE: NONE.
- ALL INSIDE RADII .010R. UNLESS OTHERWISE SPECIFIED.
- ALL EXTERNAL DIMENSIONS AFFECTED BY THE DRAFT APPLY AT THE LARGE END OF THE FEATURE, AND ALL INTERNAL FEATURES AFFECTED BY THE DRAFT APPLY AT THE SMALL END OF THE FEATURE UNLESS OTHERWISE SPECIFIED.
- 1 DEGREE DRAFT IN THE DIRECTION OF PULL IS PERMISSIBLE UNLESS OTHERWISE SPECIFIED.
- ASSEMBLY SCREWS FOR THE ENCLOSURE ARE INCLUDED. MOUNTING SCREWS FOR THE PCB AND WALL ARE SOLD SEPERATELY.
- MATERIAL / COLOR: ENCLOSURE IN ASA PLASTIC IS STANDARD IN BLACK OR GREY. SLIGHT COSMETIC SWIRLING, BLUSHING, AND/OR DISCOLORATION CAN OCCUR IN THIS ENCLOSURE DUE TO UV INHIBITORS IN THE RESIN. O-RING IN TPE IS STANDARD IN BLUE. CUSTOM MATERIALS AND COLORS ARE AVAILABLE UPON REQUEST FOR QUOTE.
- PCB SIZES ARE RECOMMENDATIONS ONLY. FINAL SIZES AND VERIFICATION OF ITS FIT ARE THE SOLE RESPONSIBILITY OF OEM.
- THIS ENCLOSURE IS CONSTRUCTED FOR INDOOR OR OUTDOOR USE TO PROVIDE A DEGREE OF PROTECTION TO THE EQUIPMENT INSIDE AGAINST THE INGRESS OF SOLID FOREIGN OBJECTS (FALLING DIRT); AND TO PROVIDE A DEGREE OF PROTECTION WITH RESPECT TO TO HARMFUL EFFECTS ON THE EQUIPMENT DUE TO THE INGRESS OF WATER (DRIPPING OR SPLASHING).

R E V I S I O N					
REV.	DRAWN BY	ECO No	DESCRIPTION	DATE	APPROVED
A	M BOYER		PRELIMINARY RELEASE	2010-Sep-17	D.C.
J	M BOYER		REMOVE SHOWN USB CUTOUT	27-Jan-12	D.C.
1.0	M BOYER		UPDATE TO AS-BUILT AND RELEASED TO MFG	23-May-12	D.C.
1.1	M BOYER	2612	REVISE STANDARD B.O.M. & INSERT SHEET 3	26-Jul-12	D.C.
2.0	R CRUZ	8513	UPDATE CONFIGURATION TABLE TO INCLUDE O-RINGS WITH ENCLOSURE	30-Dec-13	D.C.
2.1	R CRUZ	0414	UPDATE CONFIG TABLE - REMOVE BATTERY O-RING FROM -Sx CONFIGS	24-Jan-14	D.C.
2.2	M BOYER	1314	REVISE INSERT SIZE ON BOM	29-May-14	D.C.
3.0	M BOYER	1514	INCREASE ORING THICKNESS	02-Jul-14	D.C.
3.1	R CRUZ	02115	UPDATE NOTE 8	20-May-15	D.C.
4.0	R CRUZ	03115	CHANGED O-RING COLOR FROM NATURAL TO BLUE	07-Jul-15	D.C.
4.1	M BOYER	02516	INCLUDE NOTE 10	2016-May-04	D.C.
5.0	M BOYER	01718	CHANGE ORING TO BE OFF-THE-SHELF OR EQUIV.	2018-Jun-19	D.C.
5.1	M BOYER	00825	UPDATE SCREW LENGTH DESCRIPTION	2025-Jan-23	

452715(x) CONFIGURATIONS	-SW	-BS	-SS	-BW
452715 BATTERY COVER		1		1
452715 COVER (w/o BATTERY)	1		1	
452715 BASE		1	1	
452715 WALL BASE	1			1
452715 HATCH		1	1	1
6-32 PHILLIPS HEAD SCREW x .500"	4	4	4	4
8-32 PHILLIPS HEAD SCREW x .500"		2		2
6-32 x .281" OVERMOLD BRASS INSERT	4		4	
6-32 x .625" OVERMOLD BRASS INSERT		4		4
MAIN SEAL O-RING	1	1	1	1
BATTERY COMPARTMENT O-RING		1		1

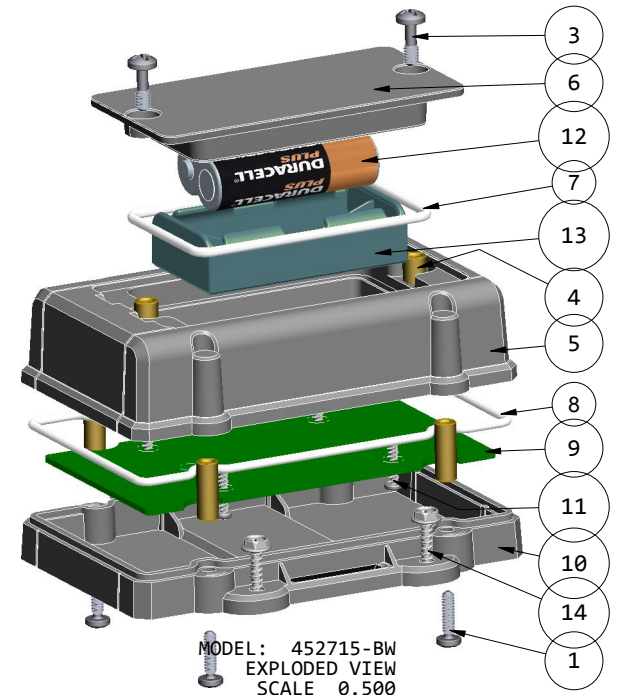
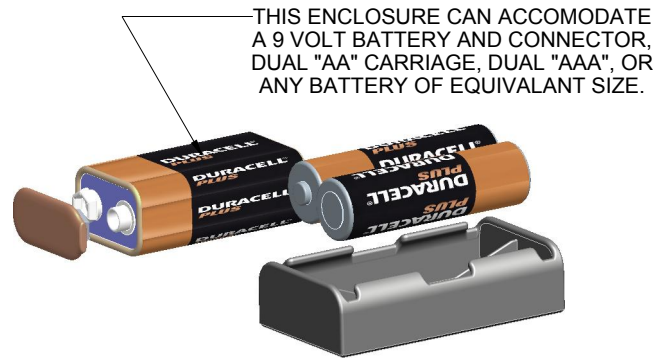

14	No6 SHEET METAL SCREW x 1.00"	410 STAINLESS	CUSTOMER SUPPLIED	4
13	BATTERY CARRIAGE AA - REFERENCE	KEYST # 2463	CUSTOMER SUPPLIED	1
12	AA BATTERY - REFERENCE	"AA" BATTERY SIZE	CUSTOMER SUPPLIED	2
11	#4 HiLo x .250" SCREW	ZINK PLATED	SOLD SEPERATELY	4
10	452715 WALL BASE - STANDARD	ASA	BLACK or GRAY	1
9	452715 PCB - REFERENCE	.062" THICK	CUSTOMER SUPPLIED	1
8	452715 O-RING, MAIN SEAL	OR-156 or EQUIV.	INCLUDED	1
7	452715 O-RING, BATT COMP	OTS	INCLUDED	1
6	452715 HATCH - STANDARD	ASA	BLACK or GRAY	1
5	452715 BATTERY COVER - STANDARD	ASA	BLACK or GRAY	1
4	8-32 x .344" CLOSED-END INSERT	TRISTAR 832X344MC	OVER-MOLDED BRASS	2
3	8-32 SCREW x .500	STAINLESS STEEL - PHILLIPS	.500" LONG	2
2	6-32 x .625" INSERT	TRISTAR 632X625C	OVER-MOLDED BRASS	4
1	6-32 SCREW x .500	STAINLESS STEEL - PHILLIPS	.500" LONG	4
ITEM	DESCRIPTION	MATERIAL	COLOR	QTY.

**BILL OF MATERIALS - Wall Base & Battery Cover**  
(See Sheet 3 for Standard Cover and Standard Base)

THIRD ANGLE PROJECTION	TOLERANCES: UNLESS OTHERWISE SPECIFIED DIMENSIONS ARE IN U.S. INCHES. X.XX = .015 X.XXXX = .001 X.XXX = .010 X.X" = 1°
DO NOT SCALE DRAWING	NEW AGE ENCLOSURES
Customer's Part No: 452715	
APPROVAL	BY DATE
CHECK	
ENG.	
SCALE	AS NOTED
DRAWN BY	2010-Sep-17
M BOYER	

**NEW AGE ENCLOSURES**  
2240 South Thornburg Street Santa Maria, CA. 93455  
ph. (805) 595-1310 fax (805) 595-1024  
[www.newageenclosures.com](http://www.newageenclosures.com)

**INDUSTRIAL UTILITY - STANDARD SXL-452715X-XXX**

SIZE	DRAWING NAME	SHEET	REV.DOC
A	452715_R5_1	1 OF 12	5.1

**452715-BW ASSEMBLY**  
COVER w/ BATTERY - WALL BASE

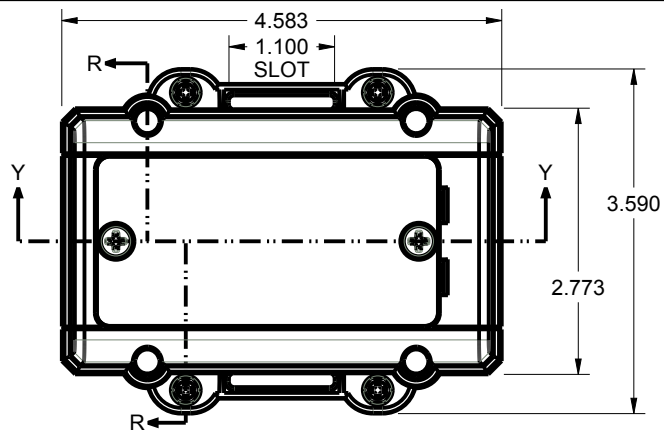

ASSEMBLY VIEW: 452715-BW  
SCALE 0.500

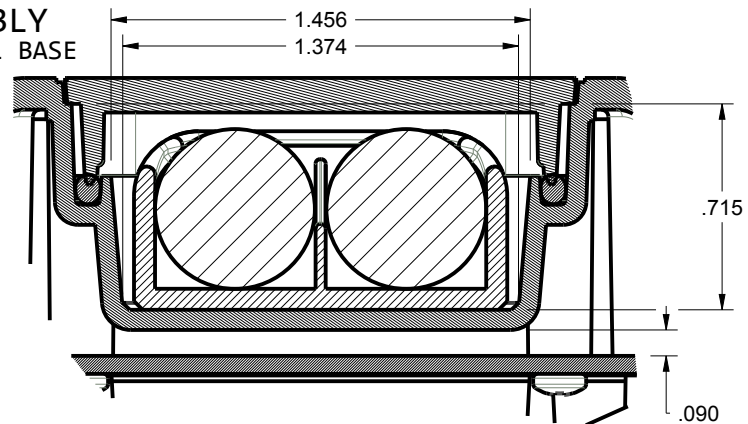

DETAIL C: 452715-BW  
SCALE 1.500

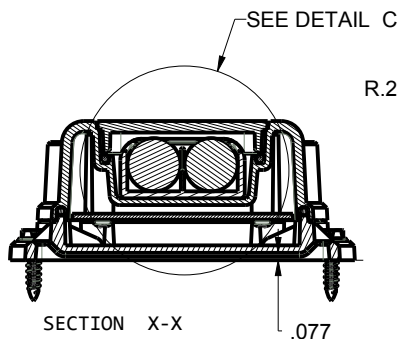
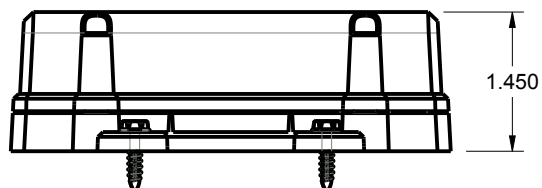

SECTION X-X

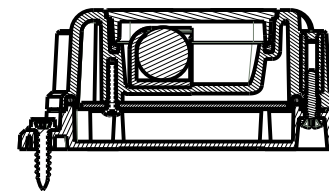
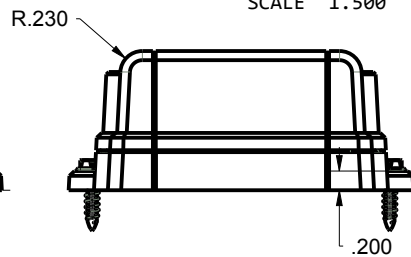

SECTION R-R

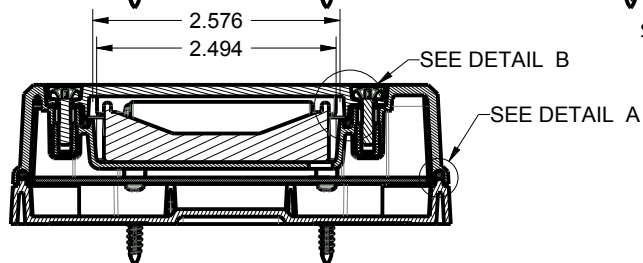

SECTION Y-Y

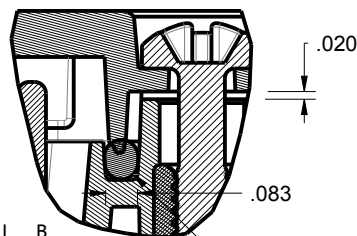

DETAIL B  
SCALE 2.000

CENTER TO BE POLISHED

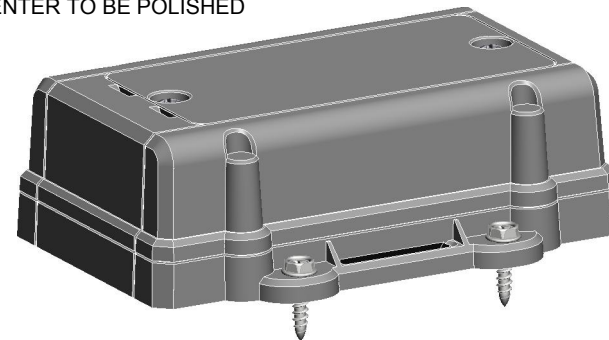

ISO VIEW: 452715-BW  
SCALE 0.600

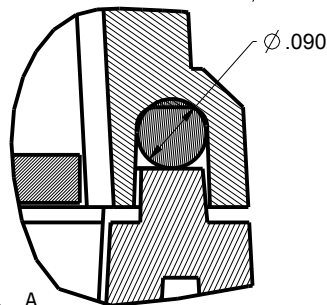
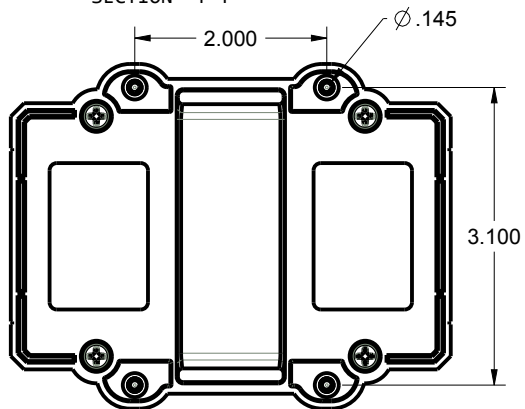

DETAIL A  
SCALE 4.000

TOLERANCES: UNLESS OTHERWISE SPECIFIED  
DIMENSIONS ARE IN U.S. INCHES.  
X.XX = .015 X.XXXX = .001  
X.XXX = .010 X.X° = 1°

NEW AGE ENCLOSURES		Customer's Part No: 452715	
APPROVAL	BY	DATE	
CHECK			
ENG.			
SCALE	AS NOTED		
DRAWN BY	2010-Sep-17		SIZE
M BOYER			A

**NEW AGE ENCLOSURES**  
2240 South Thornburg Street Santa Maria, CA. 93455  
ph. (805) 595-1310 fax (805) 595-1024  
[www.newageenclosures.com](http://www.newageenclosures.com)

**INDUSTRIAL UTILITY - STANDARD**  
**SXL-452715X-XXX**

SIZE	DRAWING NAME	SHEET	REV.DOC
A	452715_R5_1	2 OF 12	5.1

## 452715-SS ASSEMBLY

### STANDARD COVER - STANDARD BASE

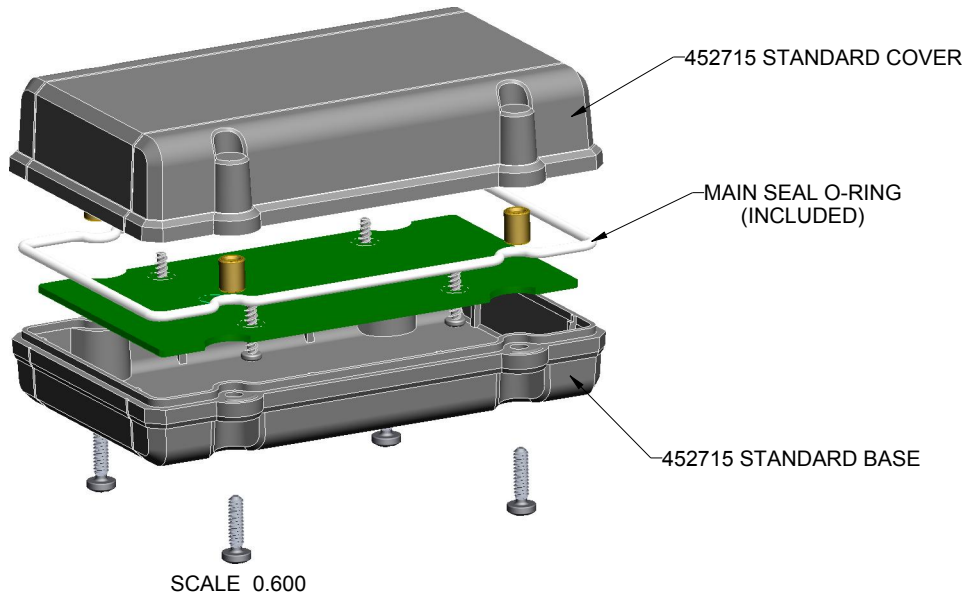

SCALE 0.600

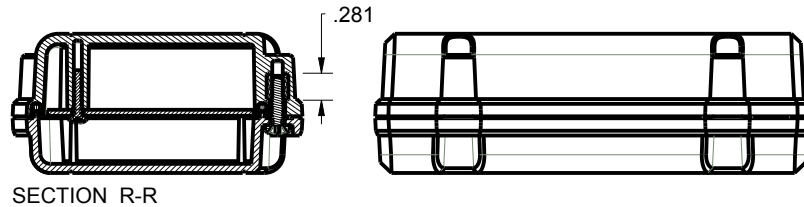
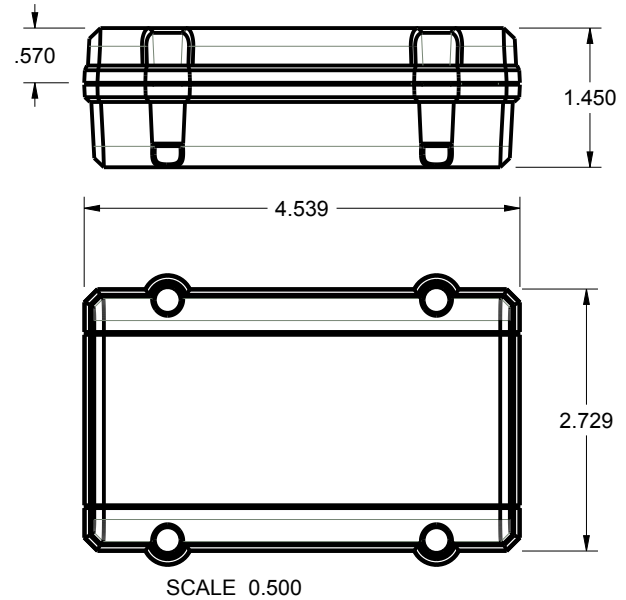

452715(x) CONFIGURATIONS				
	-SW	-BS	-SS	-BW
452715 BATTERY COVER		1		1
452715 COVER (w/o BATTERY)	1		1	
452715 BASE		1	1	
452715 WALL BASE	1			1
452715 HATCH		1		1
6-32 PHILLIPS HEAD SCREW x .500"	4	4	4	4
8-32 PHILLIPS HEAD SCREW x .500"		2		2
6-32 x .281" OVERMOLD BRASS INSERT	4		4	
6-32 x .625" OVERMOLD BRASS INSERT		4		4
MAIN SEAL O-RING	1	1	1	1
BATTERY COMPARTMENT O-RING		1		1

ITEM	DESCRIPTION	MATERIAL	COLOR	QTY.
7	#4 HiLo x .250" SCREW	ZINK PLATED	SOLD SEPERATELY	4
6	452715 PCB - REFERENCE	.062" THICK	CUSTOMER SUPPLIED	1
5	452715 O-RING, MAIN SEAL	OR-156 or EQUIV.	INCLUDED	1
4	452715 COVER - STANDARD	ASA	BLACK or GRAY	1
3	452715 BASE - STANDARD	ASA	BLACK or GRAY	1
2	6-32 x .281" INSERT	832X281C	OVER-MOLDED BRASS	4
1	6-32 SCREW x .500	STAINLESS STEEL - PHILLIPS	.500" LONG	4

**BILL OF MATERIALS - Standard Base & Standard Cover**  
(See Sheet 1 for Battery Cover and Wall Base)

TOLERANCES: UNLESS OTHERWISE SPECIFIED  
DIMENSIONS ARE IN U.S. INCHES.  
X.XX = .015 X.XXXX = .001  
X.XXX = .010 X.X" = 1°

**NEW AGE ENCLOSURES**  
Customer's Part No: 452715

APPROVAL	BY	DATE
CHECK		
ENG.		
SCALE	AS NOTED	

DRAWN BY	2010-Sep-17
M BOYER	

**NEW AGE ENCLOSURES**  
2240 South Thornburg Street Santa Maria, CA. 93455  
ph. (805) 595-1310 fax (805) 595-1024  
[www.newageenclosures.com](http://www.newageenclosures.com)

**INDUSTRIAL UTILITY - STANDARD**  
**SXL-452715X-XXX**

SIZE	DRAWING NAME	SHEET	REV.DOC
A	452715_R5_1	3 OF 12	5.1

452715-SS ASSEMBLY  
COVER - BASE

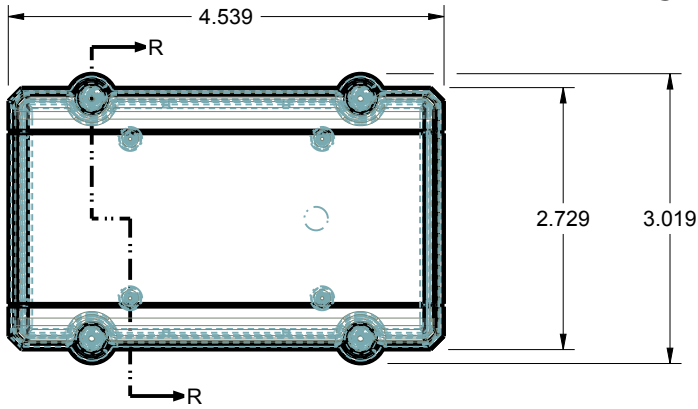

ASSEMBLY VIEW: 452715-SS  
SCALE 0.500

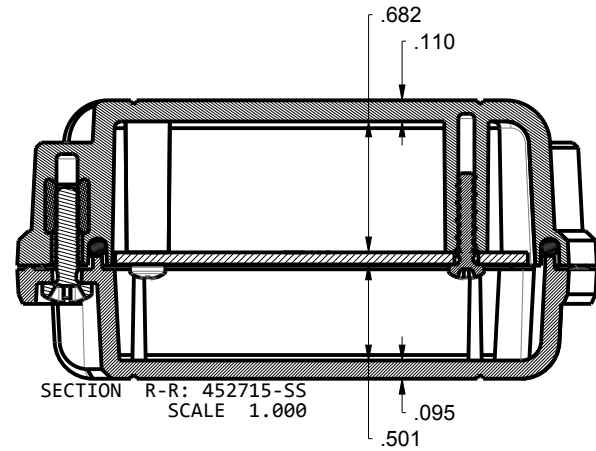

SECTION R-R: 452715-SS  
SCALE 1.000

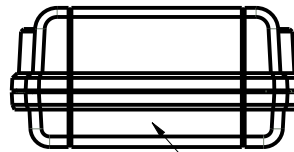
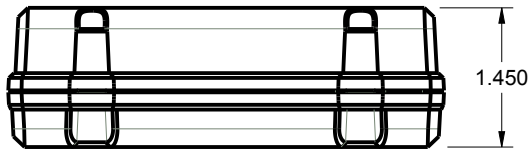

CENTER SECTION  
TO BE POLISHED

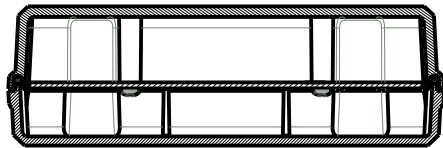

SECTION Y-Y

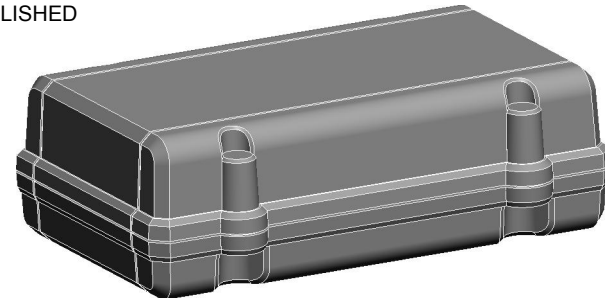

ISO VIEW: 452715-SS  
SCALE 0.600

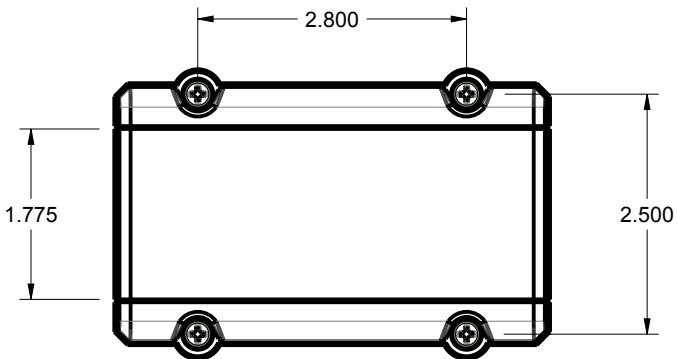

TOLERANCES: UNLESS OTHERWISE SPECIFIED  
DIMENSIONS ARE IN U.S. INCHES.  
X.XX = .015 X.XXXX = .001  
X.XXX = .010 X.X° = 1°

NEW AGE ENCLOSURES  
Customer's Part No: 452715

APPROVAL	BY	DATE
CHECK		
ENG.		
SCALE	AS NOTED	

DRAWN BY	2010-Sep-17
M BOYER	

**NEW AGE ENCLOSURES**  
2240 South Thornburg Street Santa Maria, CA. 93455  
ph. (805) 595-1310 fax (805) 595-1024

[www.newageenclosures.com](http://www.newageenclosures.com)

INDUSTRIAL UTILITY - STANDARD  
SXL-452715X-XXX

SIZE	DRAWING NAME
A	452715_R5_1

SHEET	REV.DOC
4 OF 12	5.1

**452715 BATTERY COVER**  
FOR USE IN CONFIG: -BS -BW

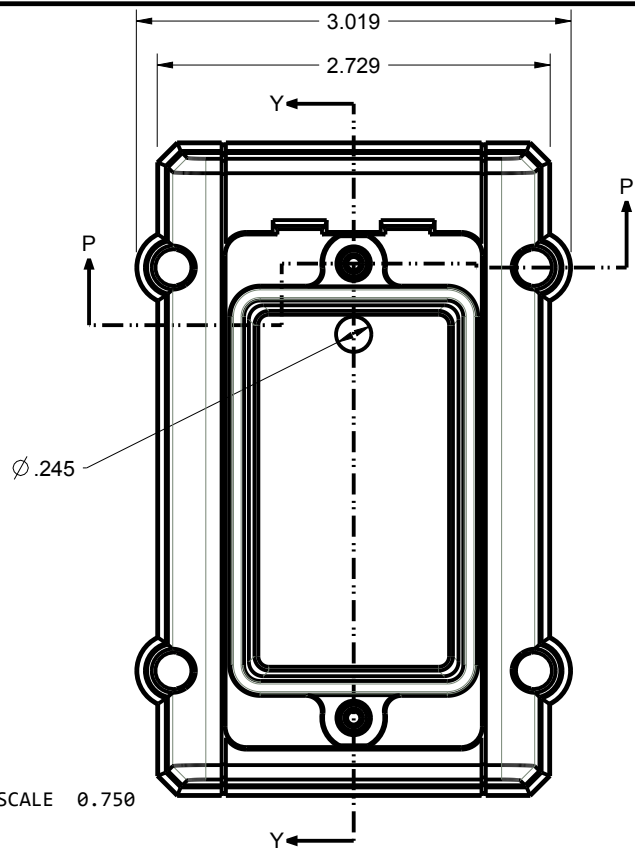

SCALE 0.750

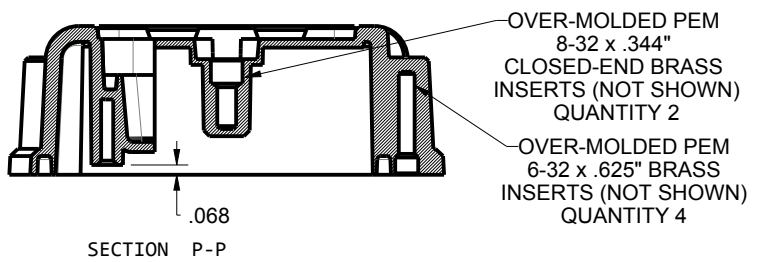
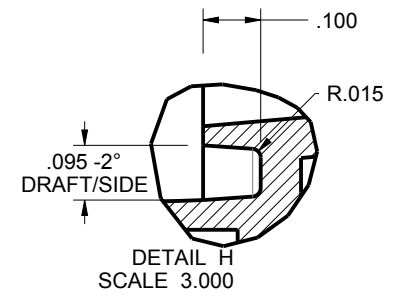
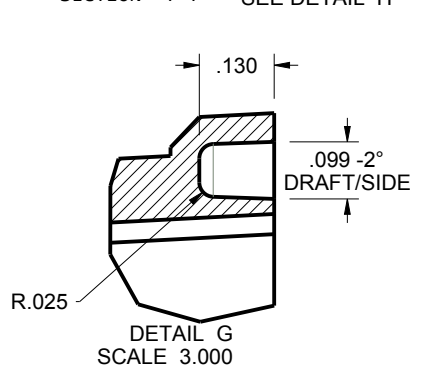
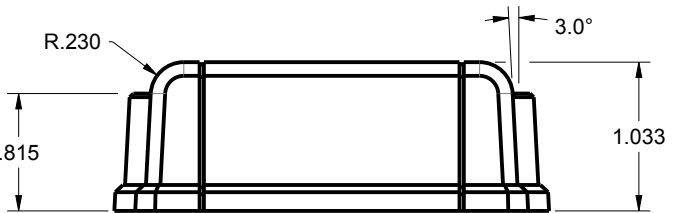
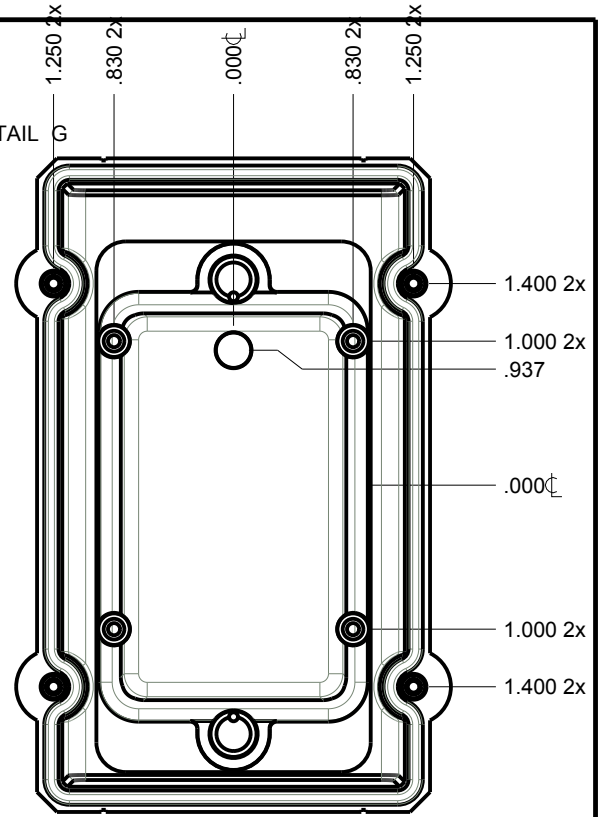
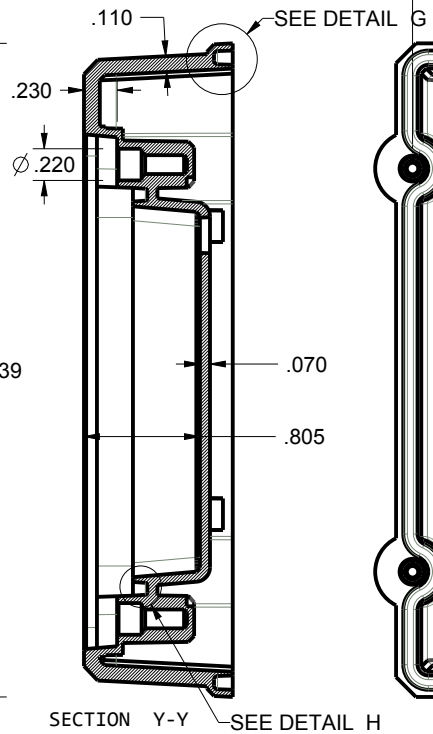
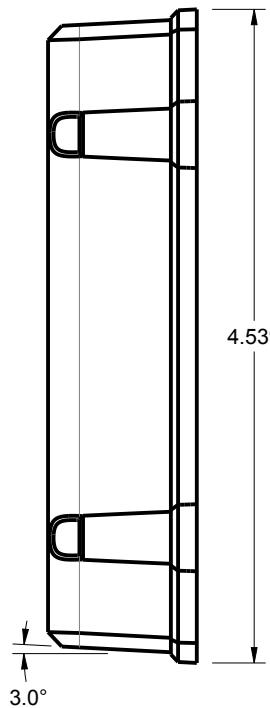

TOLERANCES: UNLESS OTHERWISE SPECIFIED DIMENSIONS ARE IN U.S. INCHES.  
 X.XX = .015 X.XXXX = .001  
 X.XXX = .010 X.X° = 1°

**NEW AGE ENCLOSURES**  
 Customer's Part No: 452715

APPROVAL	BY	DATE
CHECK		
ENG.		
SCALE	AS NOTED	
DRAWN BY	M BOYER	
	2010-Sep-17	

**NEW AGE ENCLOSURES**  
 2240 South Thornburg Street Santa Maria, CA. 93455  
 ph. (805) 595-1310 fax (805) 595-1024  
[www.newageenclosures.com](http://www.newageenclosures.com)

**INDUSTRIAL UTILITY - STANDARD SXL-452715X-XXX**

SIZE	DRAWING NAME	SHEET	REV.DOC
A	452715_R5_1	5 OF 12	5.1

**452715 COVER**  
FOR USE IN CONFIG: -SW -SS

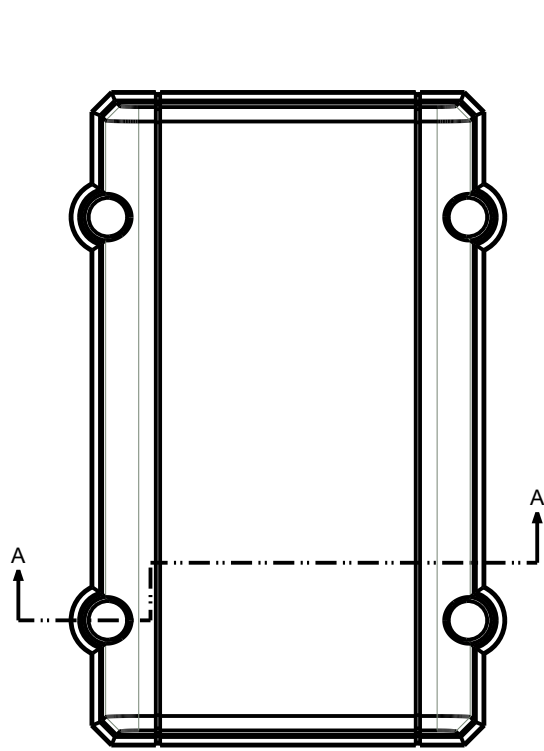

SCALE 0.750

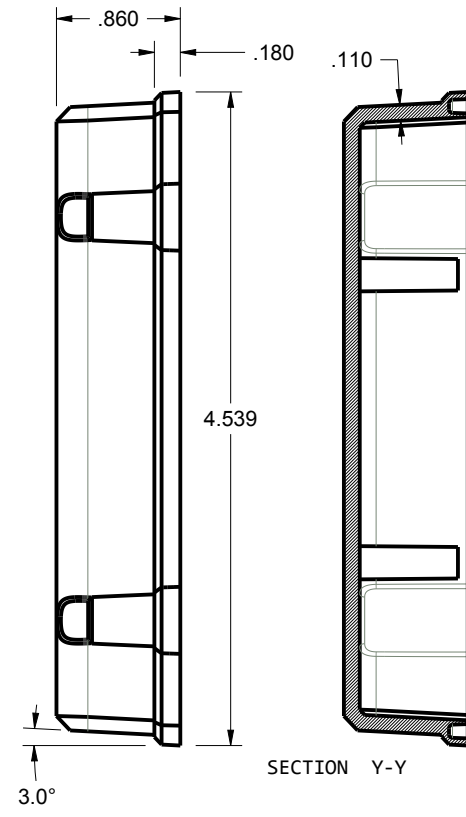

SECTION Y-Y

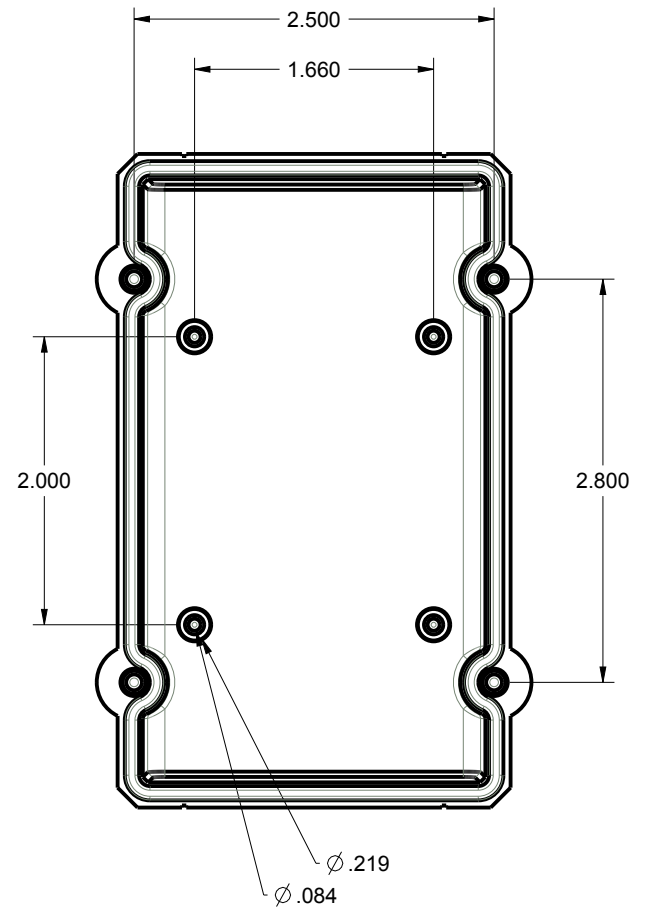

OVER-MOLDED PEM-6-32 x .281" BRASS INSERTS (NOT SHOWN) QUANTITY 4

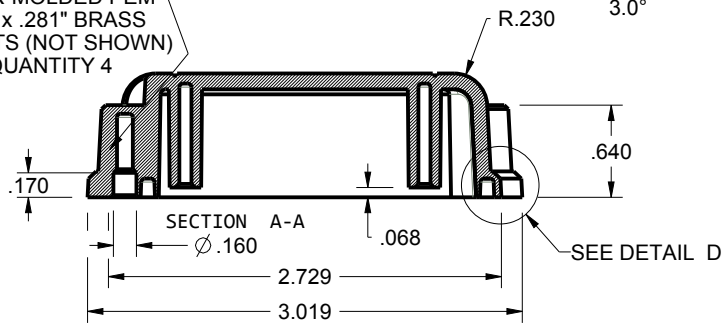

SECTION A-A

SEE DETAIL D

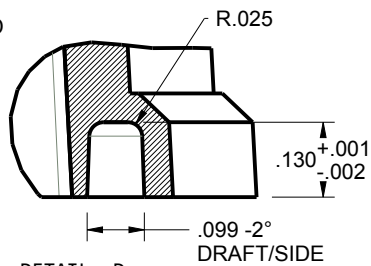

DETAIL D  
SCALE 3.000



TOLERANCES: UNLESS OTHERWISE SPECIFIED DIMENSIONS ARE IN U.S. INCHES.  
X.XX = .015 X.XXXX = .001  
X.XXX = .010 X.X' = 1°

**NEW AGE ENCLOSURES**  
2240 South Thornburg Street Santa Maria, CA. 93455  
ph. (805) 595-1310 fax (805) 595-1024

Customer's Part No: 452715

**INDUSTRIAL UTILITY - STANDARD SXL-452715X-XXX**

APPROVAL	BY	DATE
CHECK		
ENG.		
SCALE	AS NOTED	
DRAWN BY	M BOYER	
	2010-Sep-17	

SIZE	DRAWING NAME
A	452715_R5_1

SHEET	REV.DOC
6 OF 12	5.1

**452715 WALL BASE**  
 FOR USE IN CONFIG: -SW -BW

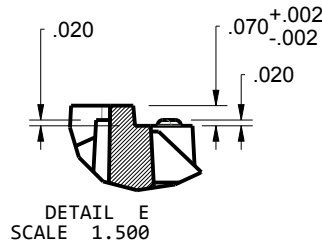
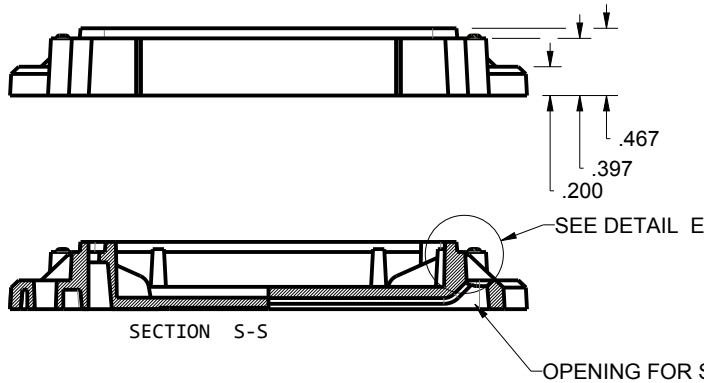
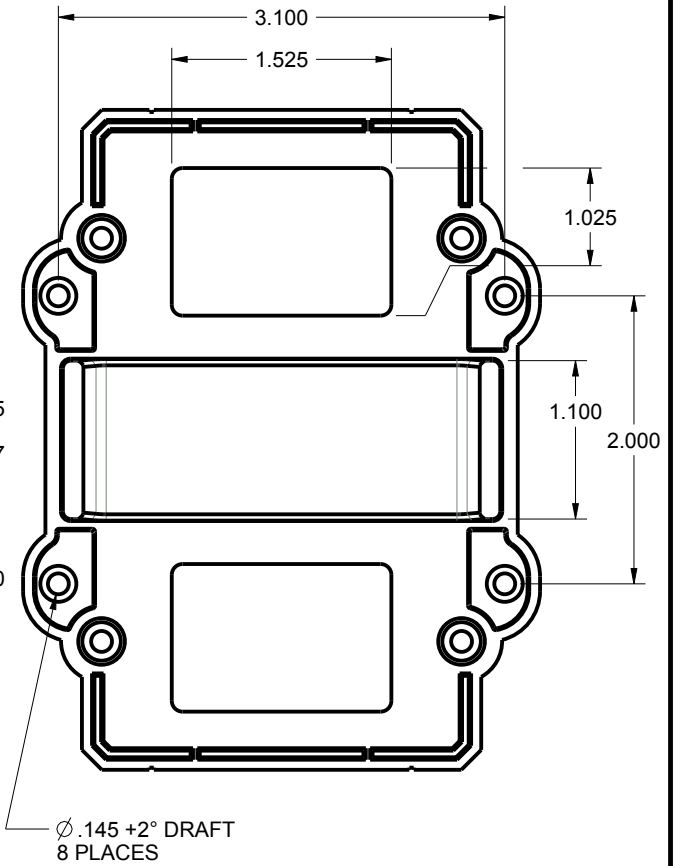
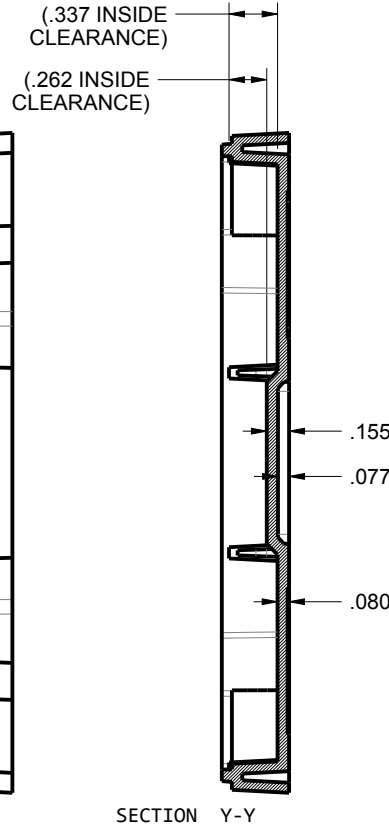
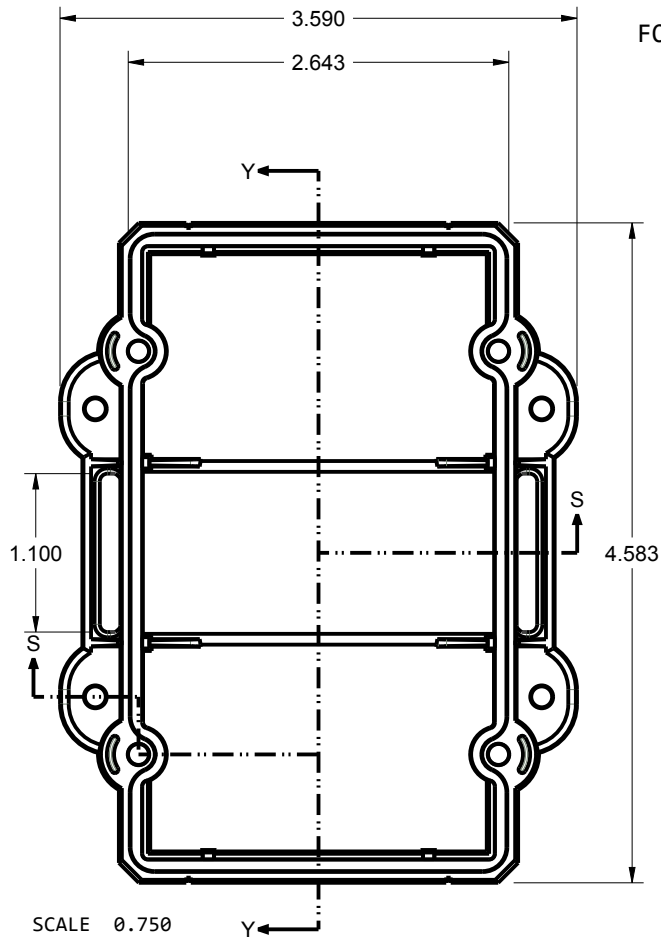

TOLERANCES: UNLESS OTHERWISE SPECIFIED  
 DIMENSIONS ARE IN U.S. INCHES.  
 X.XX = .015 X.XXXX = .001  
 X.XXX = .010 X.X° = 1°

NEW AGE ENCLOSURES  
 Customer's Part No: 452715

APPROVAL	BY	DATE
CHECK		
ENG.		
SCALE	AS NOTED	

DRAWN BY  
 M BOYER  
 2010-Sep-17

**NEW AGE ENCLOSURES**  
 2240 South Thornburg Street Santa Maria, CA. 93455  
 ph. (805) 595-1310 fax (805) 595-1024  
 www.newageenclosures.com

**INDUSTRIAL UTILITY - STANDARD**  
**SXL-452715X-XXX**

SIZE A	DRAWING NAME 452715_R5_1	SHEET 7 OF 12	REV.DOC 5.1
-----------	-----------------------------	------------------	----------------



452715 BASE  
FOR USE IN CONFIG: -SS -BS

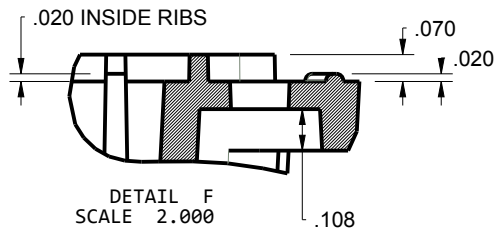
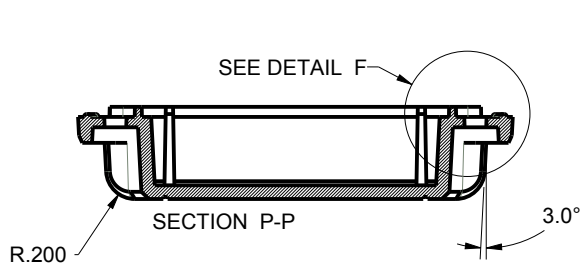
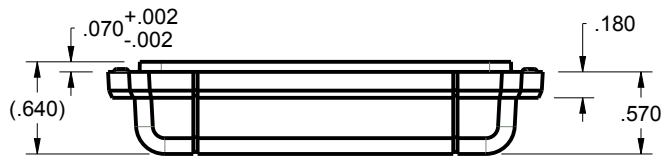
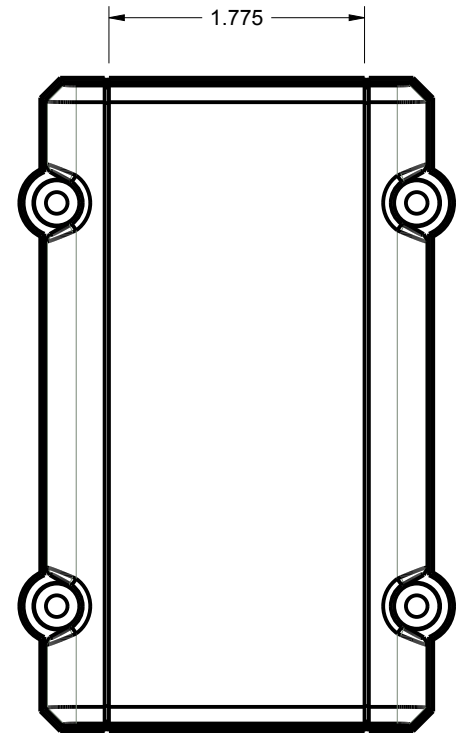
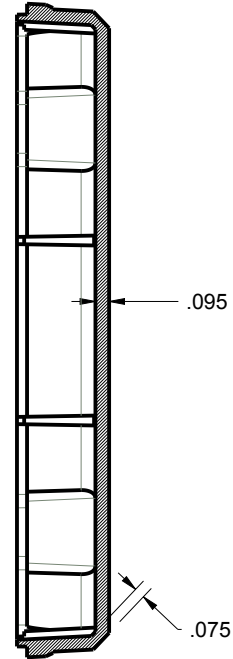
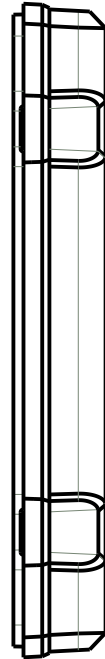
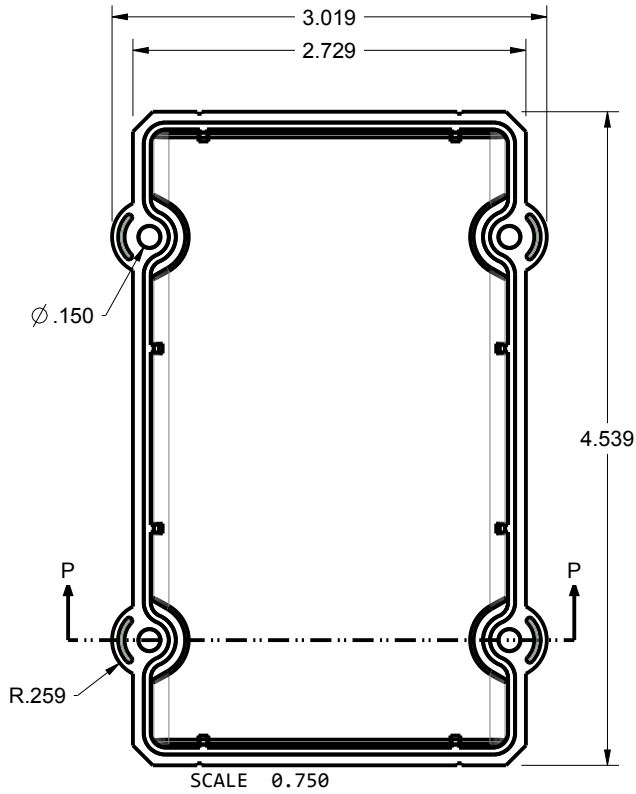

TOLERANCES: UNLESS OTHERWISE SPECIFIED  
DIMENSIONS ARE IN U.S. INCHES.

X.XX = .015 X.XXXX = .001  
X.XXX = .010 X.X° = 1°

NEW AGE ENCLOSURES

Customer's Part No: 452715

APPROVAL BY DATE

CHECK

ENG.

SCALE AS NOTED

DRAWN BY M BOYER 2010-Sep-17

**NEW AGE ENCLOSURES**

2240 South Thornburg Street Santa Maria, CA. 93455  
ph. (805) 595-1310 fax (805) 595-1024  
www.newageenclosures.com

INDUSTRIAL UTILITY - STANDARD  
SXL-452715X-XXX

SIZE A DRAWING NAME 452715\_R5\_1

SHEET 8 OF 12 REV.DOC 5.1

452715 HATCH  
 FOR USE IN CONFIG: -BS -BW

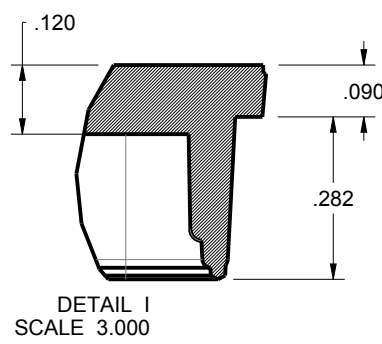
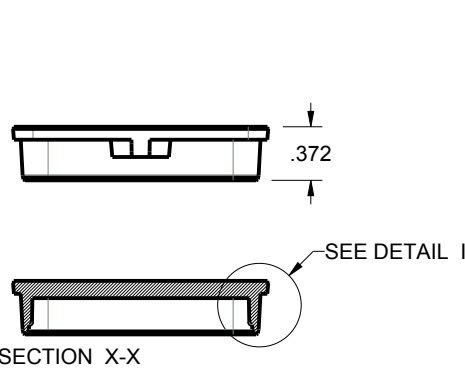
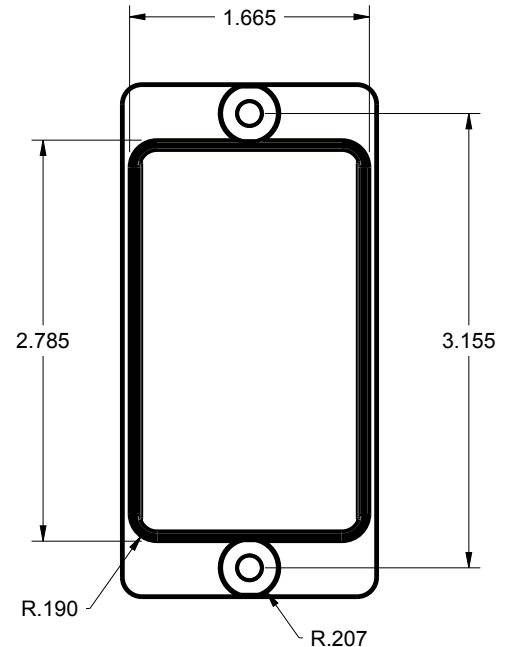
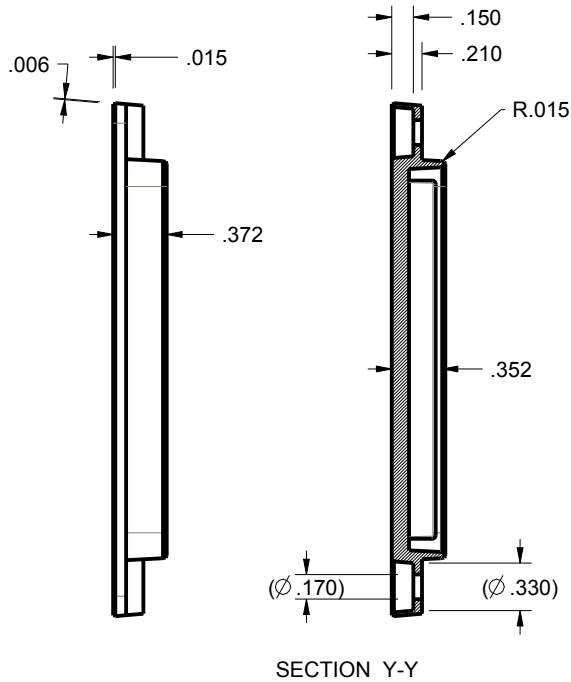
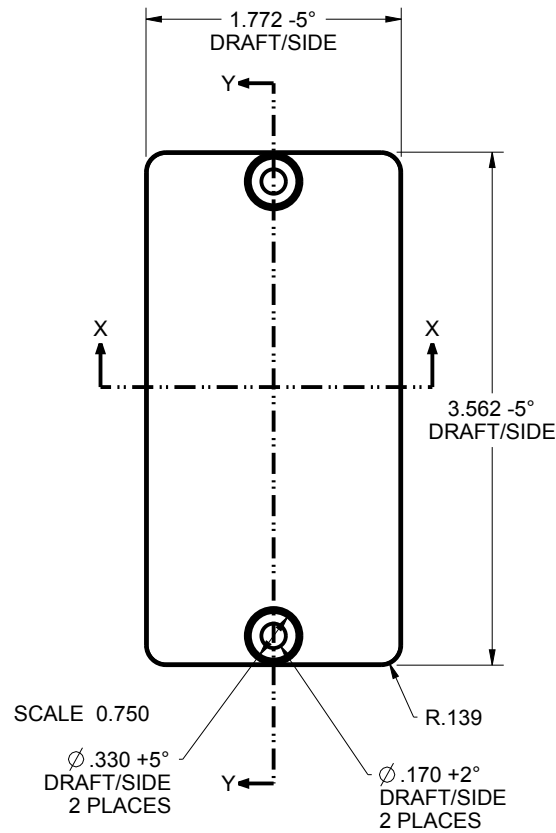

TOLERANCES: UNLESS OTHERWISE SPECIFIED DIMENSIONS ARE IN U.S. INCHES.		<b>NEW AGE ENCLOSURES</b>	
X.XX = .015 X.XXXX = .001 X.XXX = .010 X.X° = 1°		2240 South Thornburg Street Santa Maria, CA. 93455 ph. (805) 595-1310 fax (805) 595-1024 www.newageenclosures.com	
NEW AGE ENCLOSURES		INDUSTRIAL UTILITY - STANDARD SXL-452715X-XXX	
Customer's Part No: 452715		APPROVAL	BY DATE
CHECK		ENG.	
SCALE	AS NOTED	SIZE	DRAWING NAME
DRAWN BY M BOYER	2010-Sep-17	A	452715_R5_1
SHEET	9 OF 12	REV.DOC	5.1

**452715 MAIN O-RING**  
FOR USE IN ALL CONFIGURATIONS

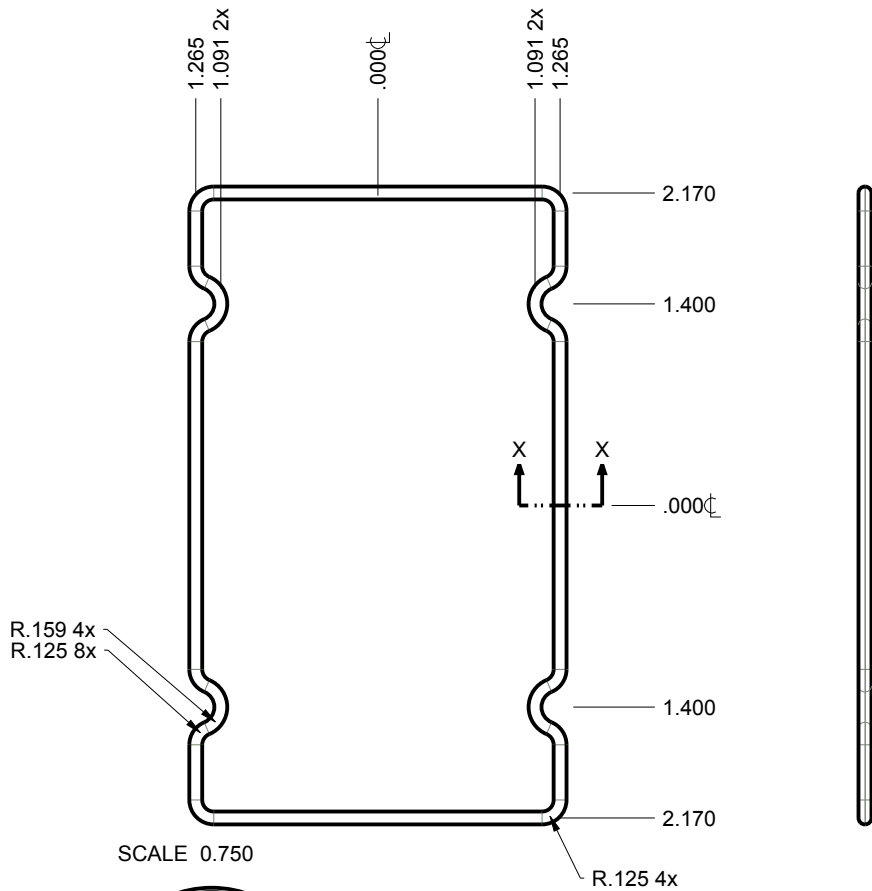

SCALE 0.750

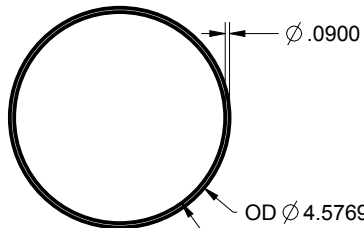

OR-156 or EQUIV.  
SCALE 0.250

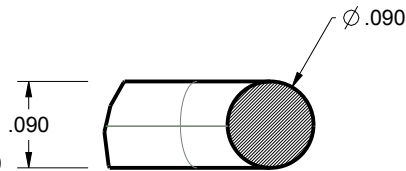

SECTION X-X  
SCALE 5.000

**452715 BATTERY O-RING**  
FOR USE IN CONFIG: -BS -BW

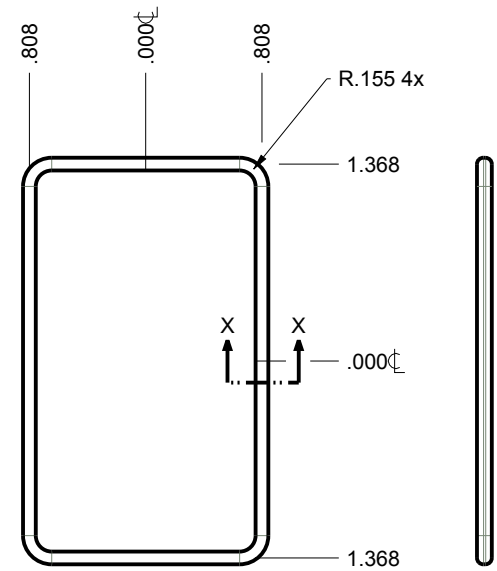

SCALE 0.750

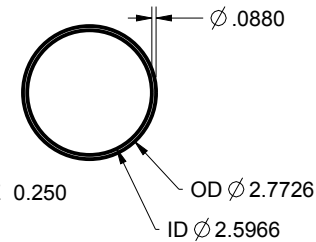

SCALE 0.250

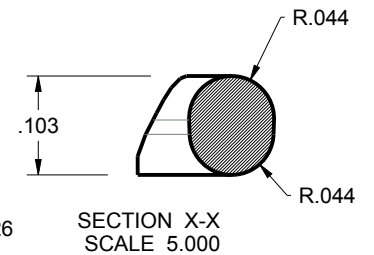

SECTION X-X  
SCALE 5.000

TOLERANCES: UNLESS OTHERWISE SPECIFIED  
DIMENSIONS ARE IN U.S. INCHES.  
X.XX = .015 X.XXXX = .001  
X.XXX = .010 X.X° = 1°

NEW AGE ENCLOSURES  
Customer's Part No: 452715

APPROVAL BY DATE

CHECK

ENG.

SCALE AS NOTED

DRAWN BY M BOYER 2010-Sep-17

**NEW AGE ENCLOSURES**  
2240 South Thornburg Street Santa Maria, CA. 93455  
ph. (805) 595-1310 fax (805) 595-1024  
www.newageenclosures.com

INDUSTRIAL UTILITY - STANDARD  
SXL-452715X-XXX

SIZE A DRAWING NAME 452715\_R5\_1

SHEET 10 OF 12 REV.DOC 5.1

# 452715 PCB - Customer Supplied

PCB SIZES ARE RECOMMENDATIONS ONLY. FINAL SIZES AND VERIFICATION OF ITS FIT ARE THE SOLE RESPONSIBILITY OF THE OEM.

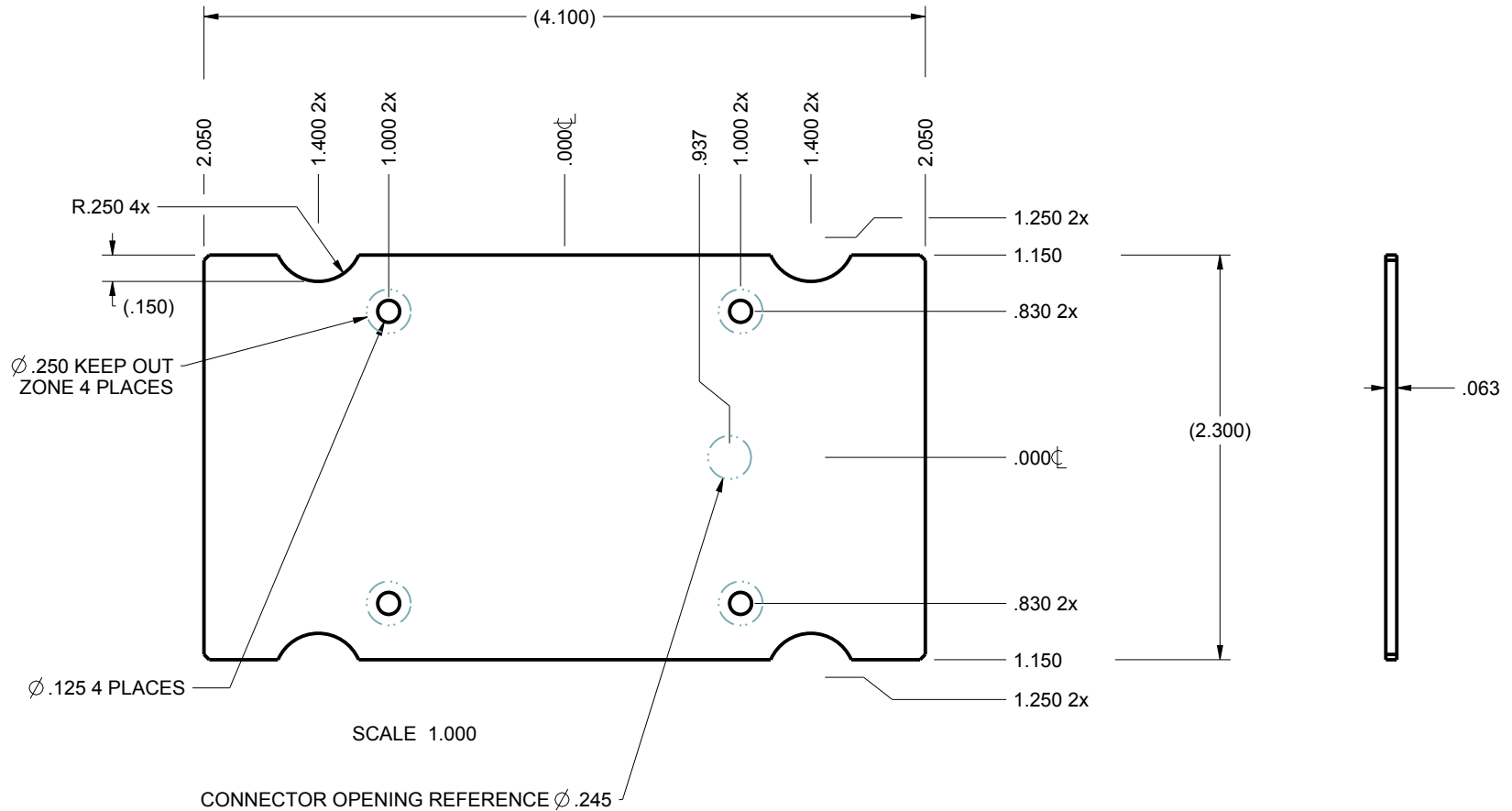

TOLERANCES: UNLESS OTHERWISE SPECIFIED  
DIMENSIONS ARE IN U.S. INCHES.  
X.XX = .015 X.XXXX = .001  
X.XXX = .010 X.X° = 1°

NEW AGE ENCLOSURES  
Customer's Part No: 452715

APPROVAL	BY	DATE
CHECK		
ENG.		
SCALE	AS NOTED	

DRAWN BY	2010-Sep-17
M BOYER	

**NEW AGE ENCLOSURES**  
2240 South Thornburg Street Santa Maria, CA. 93455  
ph. (805) 595-1310 fax (805) 595-1024  
www.newageenclosures.com

INDUSTRIAL UTILITY - STANDARD  
SXL-452715X-XXX

SIZE	DRAWING NAME	SHEET	REV.DOC
A	452715_R5_1	11 OF 12	5.1

# 452715 2nd OPERATION DETAILS

NEW AGE ENCLOSURES DELIVERS YOUR ENCLOSURE MARKET-READY WITH IN-HOUSE  
 CNC MACHINING, PAD PRINTING, ASSEMBLY, AND FULFILLMENT.  
 ALL SURFACES AND AREAS ARE AVAILABLE FOR CNC ALTERATION BY NEW AGE ENCLOSURES  
 CALL (805) 595-1310 FOR PRICING AND SCHEDULE.  
 THE INSIDE RADIUS OF ANY MACHINED FEATURES SHOULD BE NO SMALLER THAN .031"

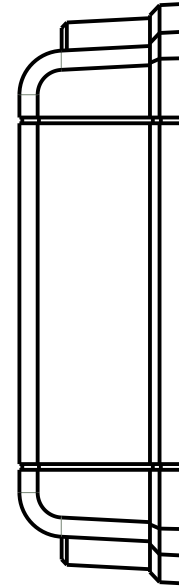
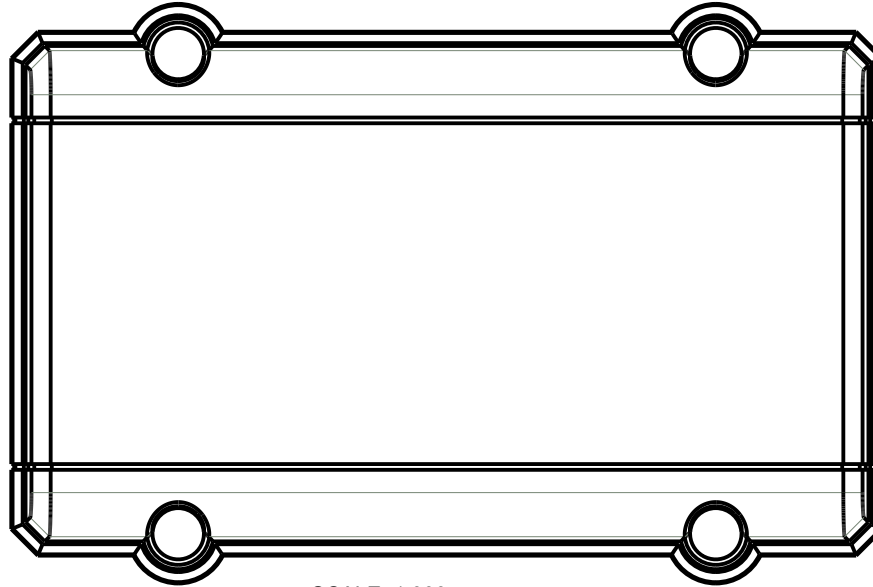
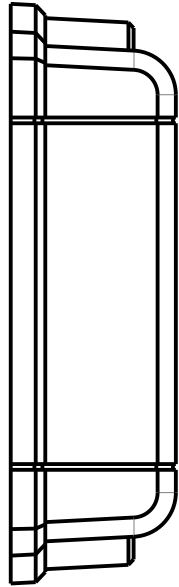

SCALE 1.000

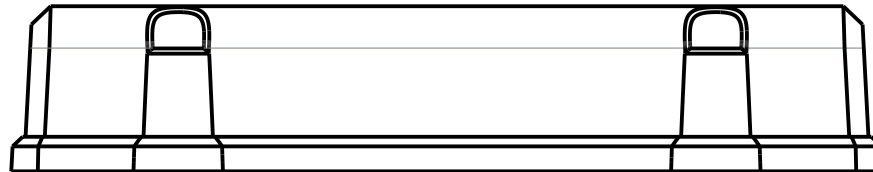

## SXL-452715-XXX COVER - ASA, BLACK

STEP NO	DESCRIPTION	CUTTER	FIXTURE	ORIENTATION	PROGRAM
1-C-C1	-	T2 = .062" EM	266	-	o1000
2-C-C2	-	T2 = .062" EM	266	-	o1000
3-C-C3	-	T2 = .062" EM	266	-	o1000

TOLERANCES: UNLESS OTHERWISE SPECIFIED  
 DIMENSIONS ARE IN U.S. INCHES.  
 X.XX = .015 X.XXXX = .001  
 X.XXX = .010 X.X° = 1°

NEW AGE ENCLOSURES  
 Customer's Part No: 452715

**NEW AGE ENCLOSURES**  
 2240 South Thornburg Street Santa Maria, CA. 93455  
 ph. (805) 595-1310 fax (805) 595-1024  
[www.newageenclosures.com](http://www.newageenclosures.com)

## SXL-452715-XXX COVER - ASA, BLACK

STEP	TYPE	FIXTURE	INK COLOR	CLICHE DESCRIPTION	CLICHE No.
4-P-P1	PAD PRINT	267	-	-	CLxxxx R1

APPROVAL BY DATE  
 CHECK  
 ENG.  
 SCALE AS NOTED  
 DRAWN BY M BOYER 2010-Sep-17

INDUSTRIAL UTILITY - STANDARD  
 SXL-452715X-XXX

SIZE A DRAWING NAME 452715\_R5\_1 SHEET 12 OF 12 REV.DOC 5.1